

EcoLectricDesign
per
l'EcoDesign in Azienda

DI
Linda Falchini

L'EcoDesign

posto a valle di un efficiente "Sistema di Gestione Rifiuti" risponde alle esigenze ambientali, culturali e sociali di un'Azienda, per :

- **prevenire** la produzione di rifiuti in conformità alla D. 2008/98/ce
 - **creare** arte e design con sottoprodotti di lavorazione
 - **mitigare** gli impatti ambientali di un'impresa
 - **sensibilizzare** al riuso dei materiali
 - **contenere** i costi di smaltimento
- **crescere** in termini di visibilità, qualità e rispetto dell' ambiente

nasce così a Messina

EcoLectricDesign

un nuovo Design, Elettrico ed Ecologico, ogni pezzo è unico e nasce dall'assemblaggio di vecchie componenti provenienti di impianti di pubblica illuminazione, come plafoniere metalliche, isolatori in ceramica, lampade e accessori vari. I materiali, ormai obsoleti, vengono decontestualizzati, reinventati e trasformati in oggetti d'Arte e di Design.

DI
Linda Schiani

Sistema Gestione Rifiuti



L'EcoDesign

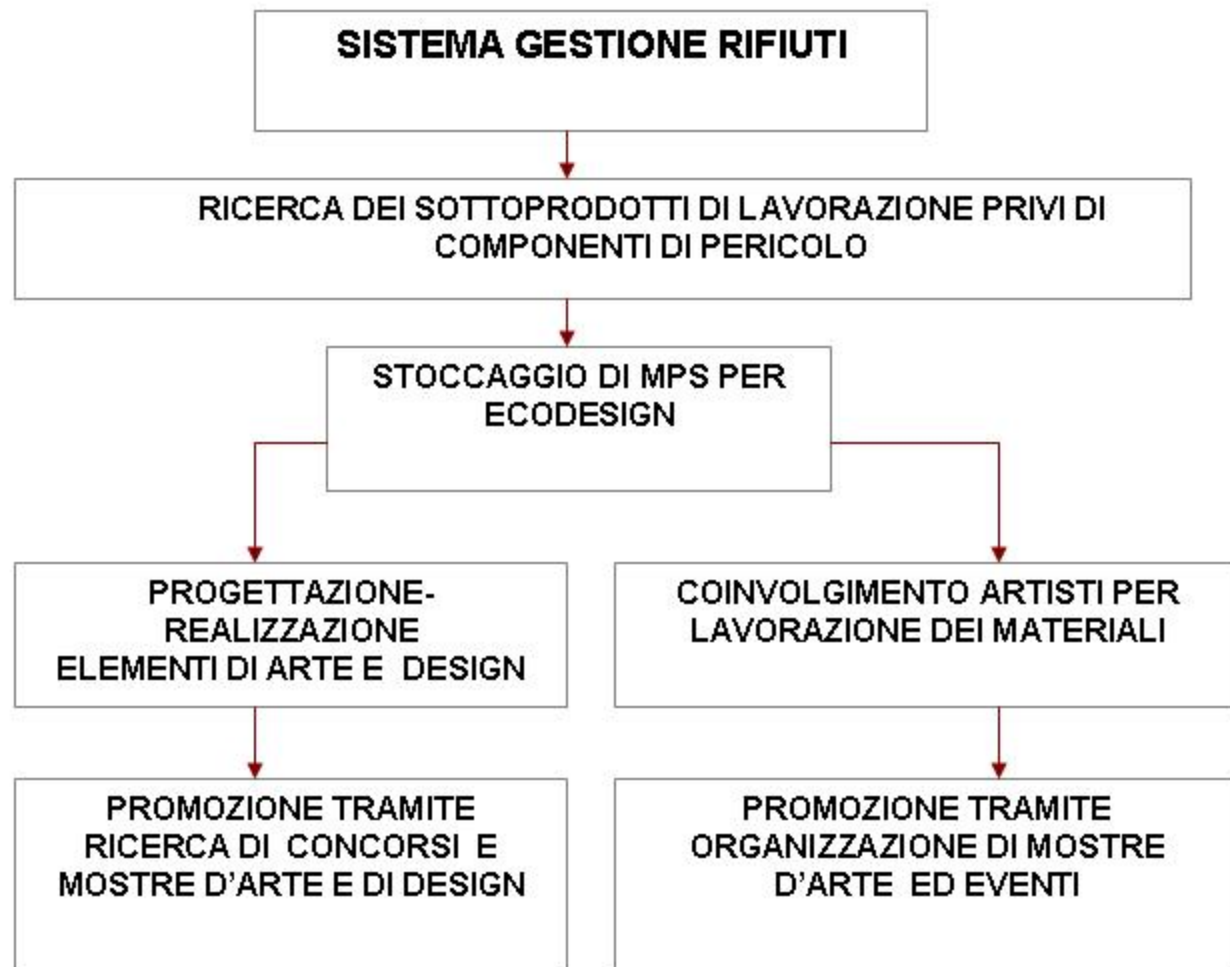

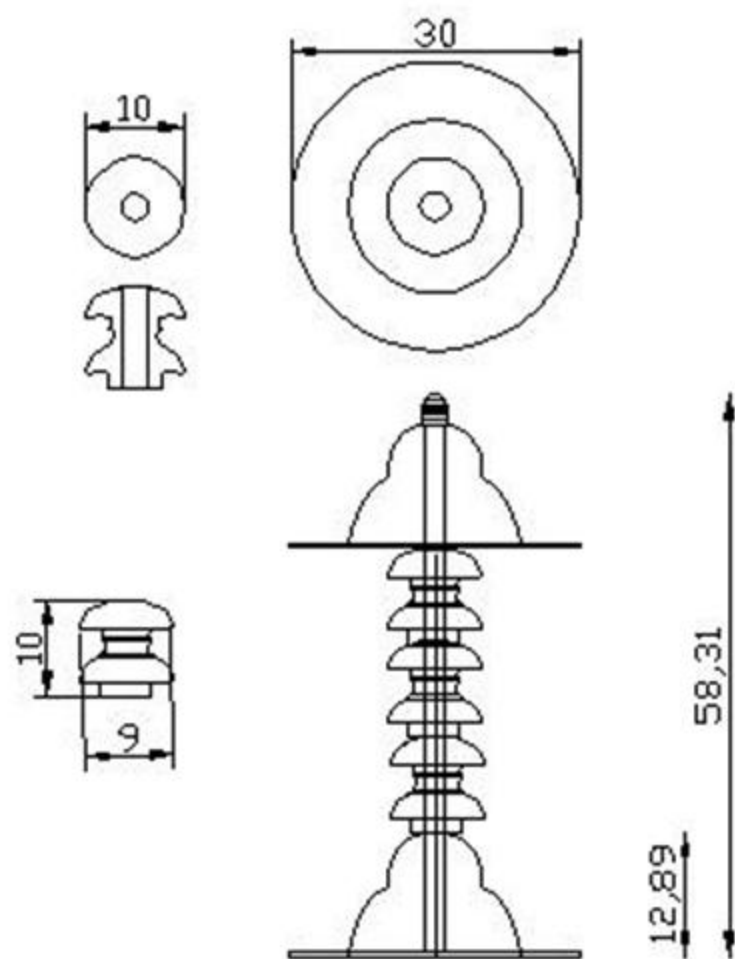

DI *Linda Soliani*

Lampada da Tavolo realizzata con isolatori in ceramica, plafoniere metalliche e un attacco di lampadina (Concorso "Young and Design 2007", Milano - "Artisti Visibili" 2007, Orientale Sicula 7.Arte, Messina- "Materia Risorta", Studio Logos, Roma) .



DI Linda Lepore

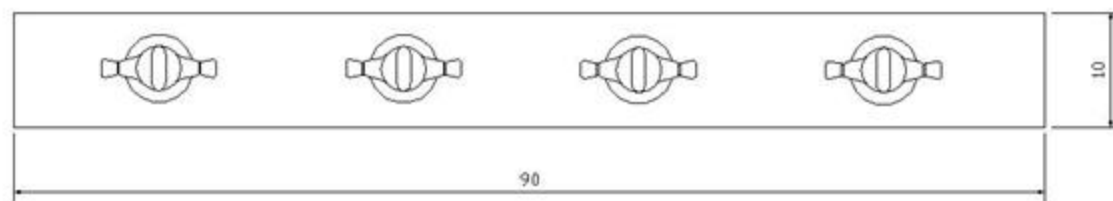

Appendiabiti realizzato con barra in legno recuperata e isolatori in
ceramica (Concorso "Young and Design 2007" Milano - Mostra "Artisti Visibili" -
Orientale Sicula7.Arte.Messina 2007- "Festa Nazionale Altra Economia" ex macello, Roma 2009)



DI *Linda Soliani*

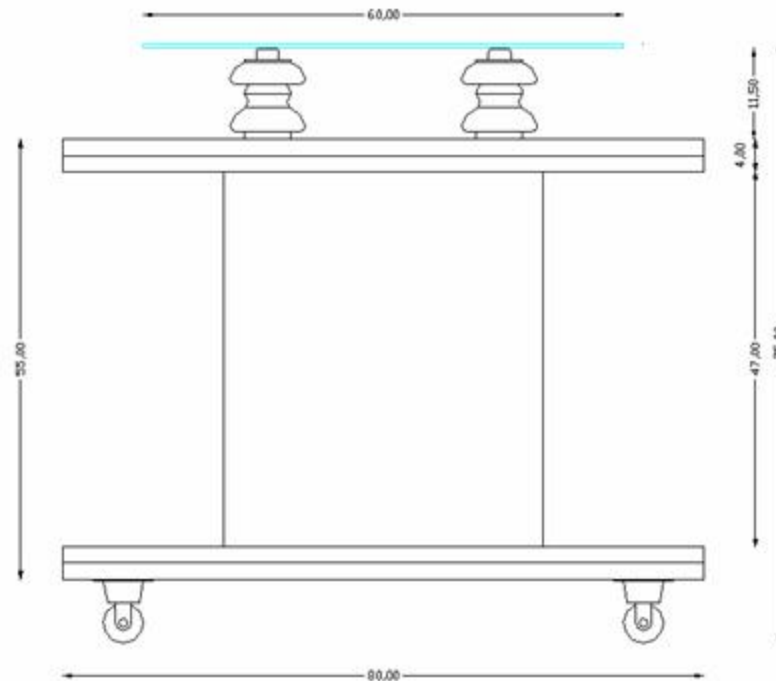

Doppio tavolo realizzato con bobina portacavo, isolatori in ceramica, tappi in sughero e ripiano in vetro (Artisti visibili –Orietalesicula7.Arte-Messina 2007)

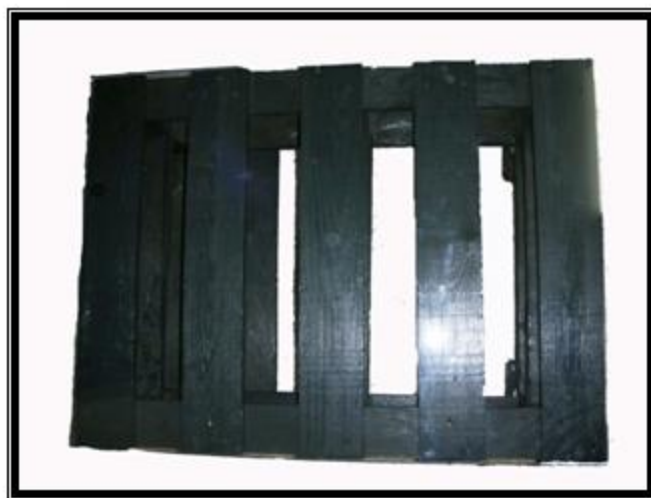
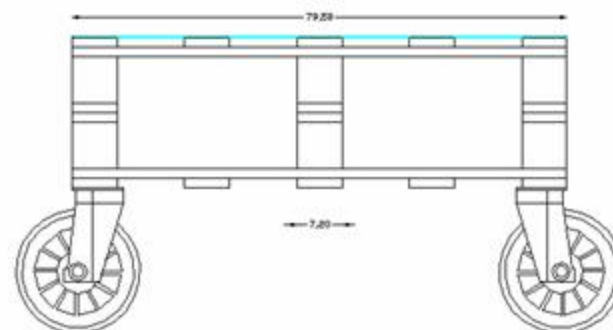
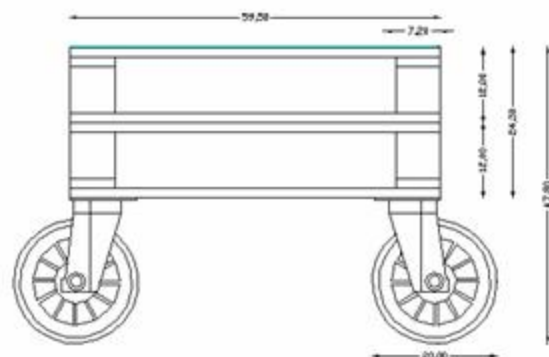

DI *Linda Schiani*

PalleTavolo, è un tavolino porta Tv- Cv- decoder, realizzato con due pallet, ruote industriali e ripiano in vetro (Selezione Finale Rilegno 2009, Milano)



Bobina Seduta, realizzata con bobina in legno, schienale e poggia piedi recuperati da una sedia da cinema

(International Design Competition Promosedia Caiazza Memorial Challenge'09)

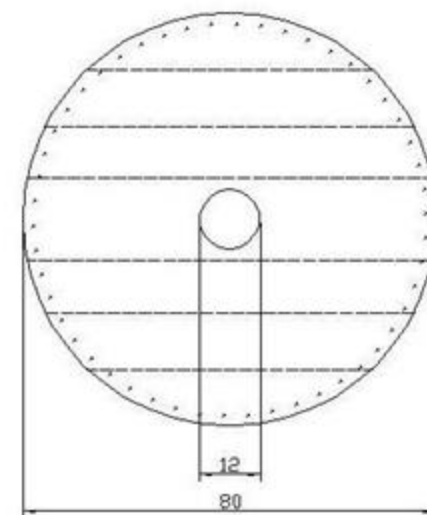
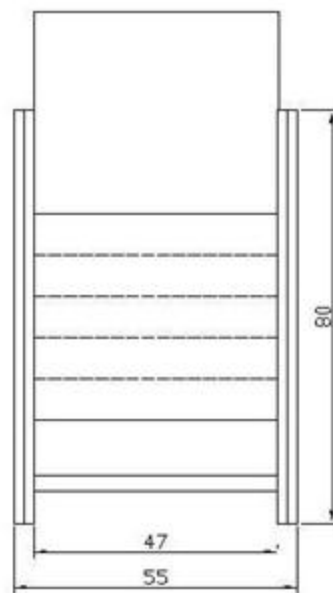
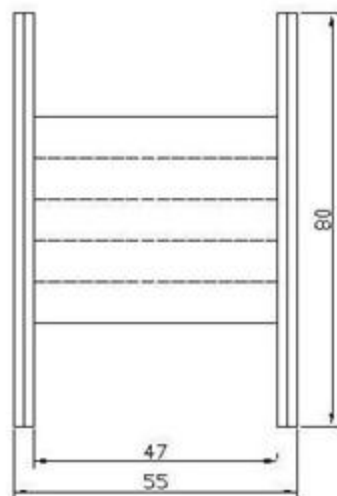

DI *Linda Schiani*

Bobine d'Artista
L'ARTE DEL RICICLO

22-26 NOVEMBRE 2008
Inaugurazione sabato 22 novembre ore 18,30



ORIENTALE SICULA
7^o PUNTO ARTE
Via G. Venezian, 7 - Messina

A CURA DI *Giulio Felipponi*



EcoLectricDesign

L'Arte del Riciclo viene
proposta agli artisti
con mostre vincolate a
materiali recuperati da
scarti d'impianti
elettrici.

Le Collettive organizzate
sono state :

"Bobine d'Artista"
"Sfere d'Artista"

Ed è in programma
"Pedane d'Artista"

Sfere d'Artista
L'ARTE DEL RICICLO

2/10 LUGLIO 2009
LABORATORIO DI ARTE DEL RICICLO VIA CROCE ROSSA IS. XII



presentazione di Gigi Giacobbe

...e altri artisti ospiti!

A CURA DI

Giulio Felipponi



Bobine d'Artista

L'ARTE DEL RICICLO



EcoLectricDesign

A CURA DI *Giuliana Solipanni*

12 artisti siciliani impegnati a trasformare in oggetti d'Arte e di Design, vecchie bobine avvolgicavo in legno dismesse (ϕ cm.60).



MANTILLA



TERESANO



QUARTARONE



PUGLIATTI



CANNISTRACI TRICOMI



VALENTINI



RANDO



MARINI



BORGIA



SERBOLI



ORIGLIO



MILITTI



Sfere d'Artista

L'ARTE DEL RICICLO



EcoLectricDesign

A CURA DI *Linda Soliani*

15 artisti impegnati a trasformare in
Oggetti d'Arte e di Design 30 sfere di
pubblica illuminazione in PVC
danneggiate (φ cm.50)



FRADA'



DI PRIMA



GOLINO



PRIVITERA

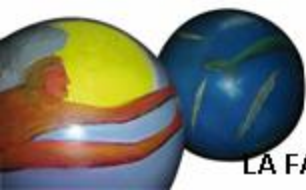

LA FAUCI



BRUNEO



BARATTA



BONANNO CONTI



MISITANO



AMOS



PAFUMI



BAMBINO



CANNISTRACI
TRICOMI



SERBOLI



AMOS

Linda Schipani

ingegnere per l'ambiente e il territorio

Via croce rossa n°5,
98124 Messina, Sicilia, Italia
lischi2000@yahoo.it
www.lischi2000.it